

Supplementary Reinforcement Structure (Dyke TYPE 2)

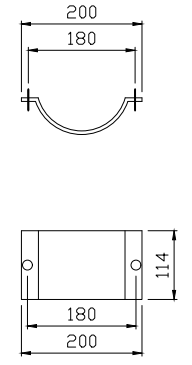

Posts Bracket

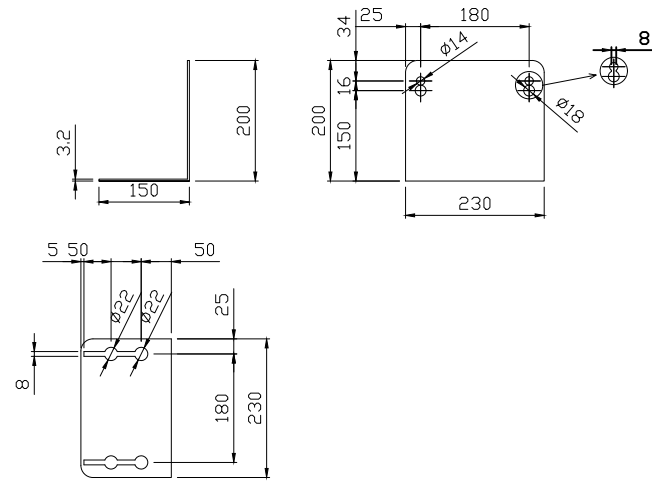
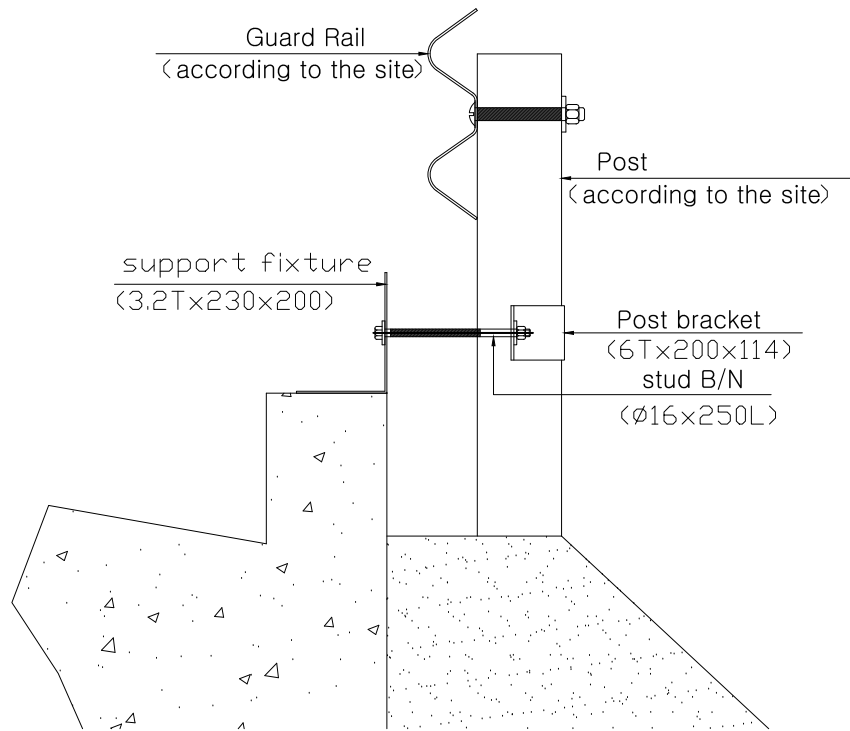
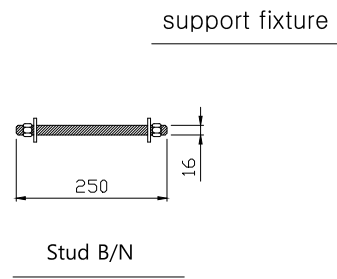

Stud B/N

NO.	Product Name	Dimension	Quantity	Remarks
1	support fixture	3.2 X 200 X 230	1	SS400
2	Posts Bracket	6T X 200 X 114	1	SS400
3	Stud B/N	Ø16 X 250L	2	
4	Anchor B/N	Ø16 X 150	2	

Drawing	Dyke TYPE 2	Design		Date		Drawing number
Project		Drawing		Scale	NON	

YOO CHANG STEEL
INDUSTRY Co., Ltd
 102, Yongdeok-ro 302beon-gil, Hallim-myeon, Gimhae-si,
 Gyeongsangnam-do, Republic of Korea
 T E L 055-346-7761-3
 F A X 055-346-7760